

Louvre Doorsets

Installation & Fitting



Please follow all the instructions carefully

Sunray doorsets are all individually made so check that the ID numbers match on the frame and the doors. Identification numbers are stamped in the centre of the top of the frame and on the barrel part of the hinges.

All doorsets supplied by Sunray have been fully assembled and tested prior to leaving the factory including panic bars, if fitted.

General care

HANDLING

Doorsets are usually delivered on a curtain-sided lorry and can be unloaded using a forklift truck.

If delivery is on an open-backed lorry they can be unloaded by crane. Use slings and ensure that no damage occurs to the door leaves and frames from the lifting operation.

- Please be aware that these doors are heavy and should be moved in accordance with manual handling regulations.
- Take particular care not to damage the hinges.
- Do not store in exposed places for long periods and protect from weather.
- Protect doorsets from mud, stray mortar and debris.

Tools and accessories required for installation

- Wedges and blocks
- Shims/packers
- Drill and suitable masonry bit
- Pozi screwdriver
- 17mm spanner
- Set square
- Spirit level
- Mastic

Storage

Doorsets can be stored flat or upright. If storing flat, store on a palette or wooden bearers to protect the hinges and lugs, with wooden bearers placed on top to support the door leaf.

Do not store or stack anything on top of the doors/frames.

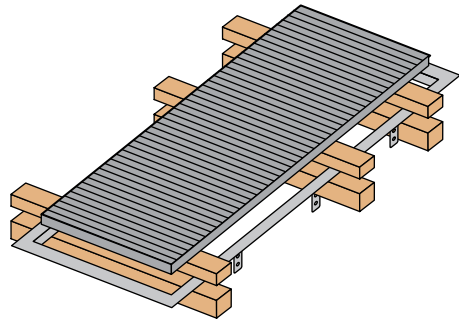

Preparation of the opening

Measure and check the structural opening in several places to ensure that it is square, level and to the correct dimensions.

The frame should be inserted into the structural opening from the outside of the building.

If the brickwork is not yet complete, wooden blocks or spare bricks may be used to support the frame. See below.

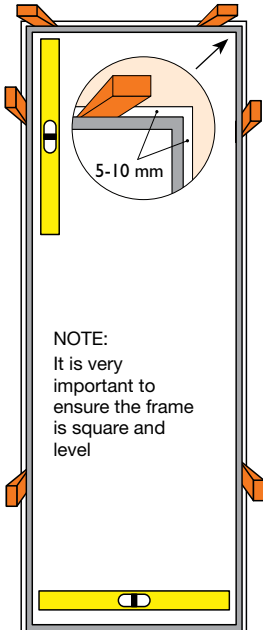
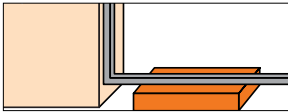

Securing the frame to the opening

The frame should be fixed with M12 x 75mm sleeve anchor bolts (supplied), through the lugs welded to the frame or through frame fixing. This choice will be dependent on the cavity situation. Use only 1 sleeve anchor bolt per lug.

SELECT THE CORRECT HOLE IN THE LUG

The frame must be fixed with the hole nearest to the centre of a brick as possible, to ensure maximum secure fixings (see diagram opposite).

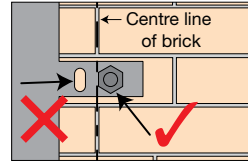

Despite the heavy duty nature of the frame, distortion can take place. For the doors to function correctly, it is imperative that the frame is bolted in level and without distortion.

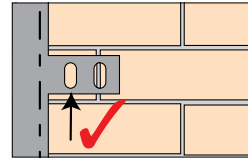
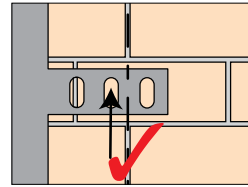

SHIMS

Gaps between structural opening and frame must be packed with steel shims (not supplied).

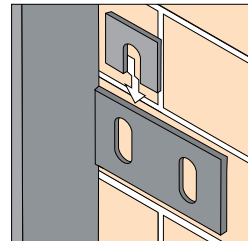

Fixing-in overpanels/ side panels

Where overpanels or side panels are not factory fitted, fix them in using M10 bolts (supplied) through the single hole fixing lugs on the rear of the frame.

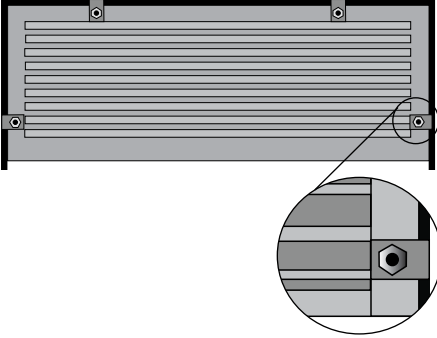

Hanging door leaf(s)

The door leaf(s) are lifted onto the hinges. Nylon bushes are already pushed into the female part of the hinge, to create zero maintenance.

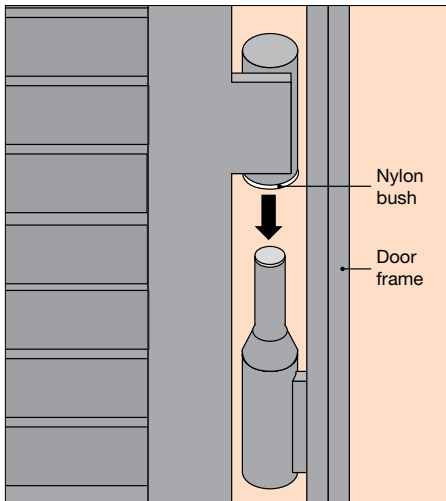

Door furniture

Fit Sunray 6000 Hasp and Staple as per instructions (see page 47). The panic bar system would have been assembled in the factory, so it will require screwing on as per instructions (see overleaf for setup).

3-way locking will already be assembled on the door leaf but may need lubrication.

**Ensure smooth operation of the doors.
Drill upstand and lintel to accommodate locking and draw bolts.**

Finish

Sunray doorsets are supplied with either a powder coat finish or prime red oxide finish, ready for on site painting after installation.

Sunray cannot accept responsibility for any deterioration of the doorsets if the finish coats have not been applied within a reasonable period. The storage location should reflect this.

Operation and maintenance

Doorsets are of a robust construction and simple operation. Therefore other than good housekeeping, they require minimal maintenance.

Panic bar set-up

(1) PULL THE DOOR CLOSED AND CHECK:

- That the top catch (A) releases against the keeper plate.
- That both top and bottom shoots (B) have adequate overlap.

TOP

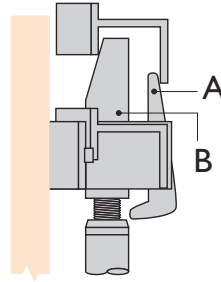

BOTTOM

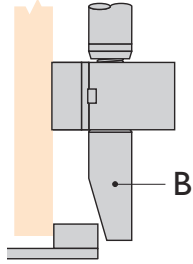

(2) DEPRESS THE PUSH BAR AND OPEN THE DOOR ENSURING:

- That both shoots fully withdraw (A) with adequate clearance.
- The top catch (B) engages and retains the shoot in the withdrawn position. Correct operation of the push bar mechanism is ensured.

TOP

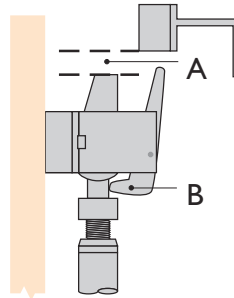

BOTTOM

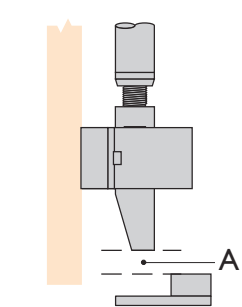

(3) TO ADJUST:

- Remove the retaining screws (A).
- Rotate (B) to shorten or lengthen as required. Full rotation must always be made ensuring that the angled side of the shooter faces the door.

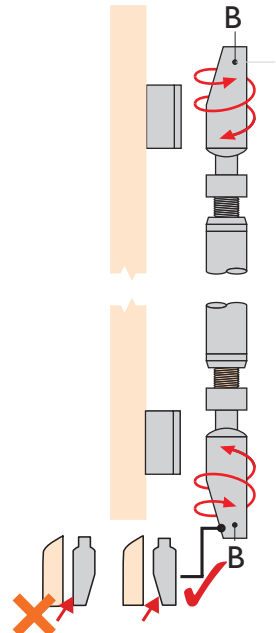
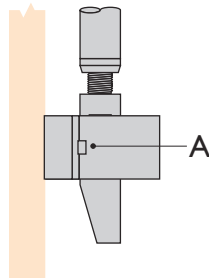
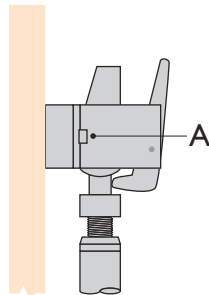

Louvre doorset troubleshooting

Problem	Possible cause	Corrective action
Doors do not fit in frame.	Wrong door being offered.	Check the ID numbers to ensure they are all the same.
Doors will not drop onto hinges.	Male and/or female hinges bent.	Re-align.
	Frame bowed.	Shim frame to bring square.
Doors will not close.	Mortar fouling closing surface.	Clean out and re-try.
Doors will not shut to frame at top and/or bottom.	Frame out of square.	Correct by shimming as necessary.
	Door bent in storage.	Straighten.
	Hinges damaged.	Re-align.
Door handle fouls louvre or stiffening bar on back of door.	Handle bent during handling.	Straighten handle.
Draw bolts will not engage in the frame.	Debris fouling receiving hole.	Clean out and re-try.
	Frame not level or square.	Correct by shimming.
Door leaves not level at centre.	Frame not level or square.	Correct by shimming.
	Nylon spacers missing.	Fit nylon spacers.
Panic furniture not operating properly.	External hasp misaligned.	Remove, rotate and re-fit.
	Panic furniture on incorrect door.	Check ID numbers match.

For further technical details of all our locking systems refer to www.sunraydoors.co.uk